

GENERAL INFORMATION

The Chemetron Fire Systems Beta Series Systems are automatic suppression systems using the FM-200 chemical agent and consisting of four basic components and their associated accessories.

- FM-200 Components
- Control Panels
- Detection and Alarm Devices
- Completer Kits

Features

- 1** The FM-200 components consists of agent containers, container supports (racks), and discharge nozzles.
- 2** The control panel is the brains of the system and is used to monitor the detection and accessories.
- 3** The detection, alarm devices, and accessories are the external devices that act as the eyes and voice of the system as they give audible or visual signals.
- 4** The completer kits consist of warning signs, hoses, connection fittings, pressure gauges or solenoid valves, and the actuator required to operate the cylinder valve.

The system and its components are agency tested for total flooding applications and should be used in accordance with the guidelines contained in National Fire Protection Association Standard 2001. A total flooding application can be defined as injecting FM-200 into an enclosure or volume having the structural integrity to retain the agent during and after discharge. The design of such a system requires that the FM-200 chemical agent be discharged from its container within 10 seconds and be thoroughly mixed throughout the protected volume, reaching a minimum concentration level of 7%, but not exceeding 9% in normally occupied spaces.

BETA SERIES SYSTEM EQUIPMENT DESCRIPTION

Cylinder and Valve Assembly

FM-200 is stored in specially designed cylinder assemblies. Beta series cylinders are available in three different capacities and are charged with FM-200 to a filling density up to 70 lb./ft³ (1121 kg/m³) of cylinder volume. All cylinders are super-pressurized with dry nitrogen to a pressure of 360 psig (2482 kPa), at 70°F (21°C). Each cylinder is equipped with an identification nameplate indicating the quantity of FM-200.

The standard cylinder assembly, having a rigid dip tube, is designed for mounting in a vertical position only. The cylinder assembly is composed of a cylinder, dip tube, and cylinder valve.

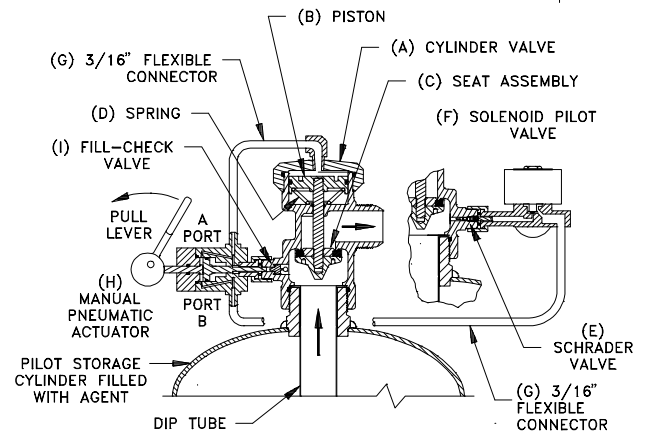
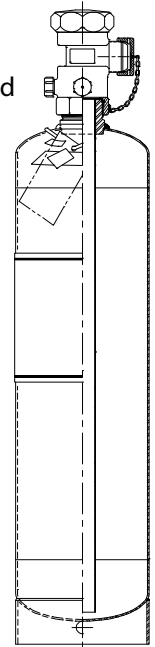

Cylinder Valve - Standby Mode

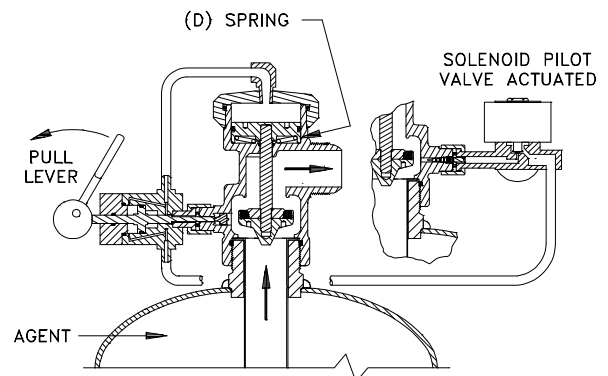

Cylinder Valve - Actuated Mode

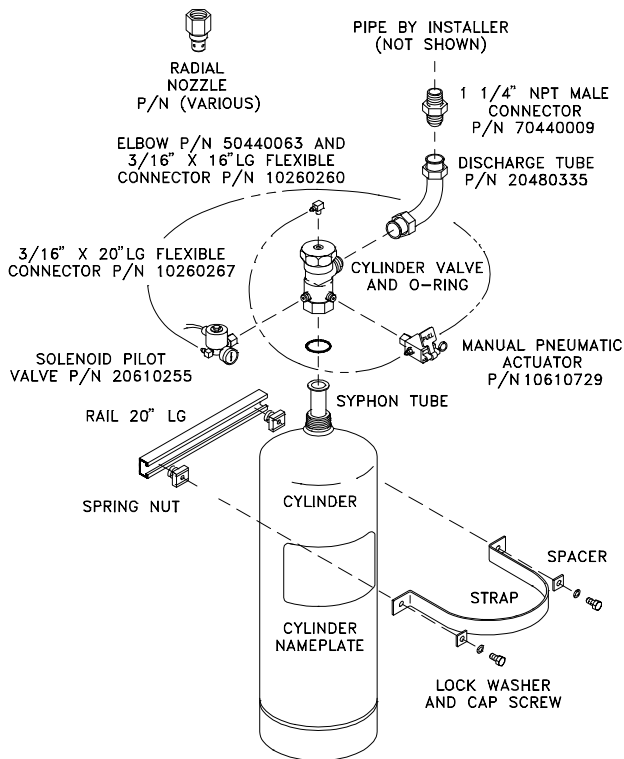

BETA SERIES FM-200 CYLINDER ASSEMBLY
WITH COMPLETER KIT, MOUNTING BRACKET, AND NOZZLE

Cylinder	Stock Number	Fill Capacity			
		Minimum		Maximum	
		lb	kg	lb	kg
40 lb.	10480992	21	9.5	41	18.6
55 lb.	10480980	28	12.7	55	24.9
95 lb.	10480991	48	21.8	96	43.5

A Cylinder: The welded seam steel cylinders are manufactured to the requirements of the Department of Transportation (DOT) for compressed gas and have external neck threads for cylinder valve connection.

B Dip Tube: A flanged dip tube extends from the cylinder neck down to within approximately 5/8 in. (16 mm) of the bottom of the cylinder. The flange, clamped between the top of the cylinder neck and the cylinder valve, supports the dip tube.

C Cylinder Valve: A pressure operated cylinder valve having a forged brass body and cap is attached to the cylinder neck and serves to control the flow of FM-200 from the cylinder. A synthetic rubber seat disc and disc carrier are connected by a stem to an operating piston at the top. The piston to valve ratio is approximately 3 to 1.

The cylinder valve has five connections, as follows:

1 Manual-Pneumatic Actuator Connection: This is a threaded connection housing a check valve and serves as the attachment point for the manual-pneumatic actuator and for cylinder filling operations.

2 Pressure Gauge/Solenoid Pilot Valve Assembly Connection: This is a threaded connection housing a check valve and serves for the attachment of:

- Solenoid pilot valve assembly (with pressure gauge) for pilot cylinders.
- Pressure gauge assembly for all other system cylinders.

3 Safety Disc Connection: A frangible safety disc is connected to the valve body and serves as a pressure relief device to protect the cylinder against excessive internal pressure. Its disc rupture point is in the range of 850 psi to 1000 psi (5860 kPa to 6895 kPa).

4 Discharge Connection: A 1-1/2 in. (40 mm) O.D. flare connection serves as the discharge port.

5 Pilot Connection: A 1/4 in. (8 mm) NPT tap in the cylinder valve cap provides a means of applying pilot pressure above the operating piston.

COMPLETER KIT COMPONENTS

Either a primary or slave completer kit is required to complete the installation of each FM-200 cylinder. The components included in the primary and slave completer kits are detailed in the following chart.

Description	Completer Kits	
	Primary 20480642	Slave 20480643
	Quantity	Quantity
Solenoid valve	1	0
Discharge tube	1	1
Manual-pneumatic actuator	1	0
3/16" flex hose 16" long	1	1
3/16" flex hose 20" long	1	1
90° Elbow 1/4" Fl x 1/4" MNPT	1	3
1-1/4" Male connector	1	0
1/4" Male connector	0	1
Pressure gauge	0	1
Warning sign	1	0
Cylinder Nameplate	1	0

Solenoid Pilot Valve Assembly

The system utilizes a solenoid pilot valve assembly to provide pilot pressure for actuation. The solenoid must be electrically supervised by a recognized fire suppression system control panel.

The solenoid pilot valve assembly includes a pressure gauge and adapter with swivel nut, vented elbow, and O-ring seal that is attached to the pressure gauge connection of the cylinder valve.

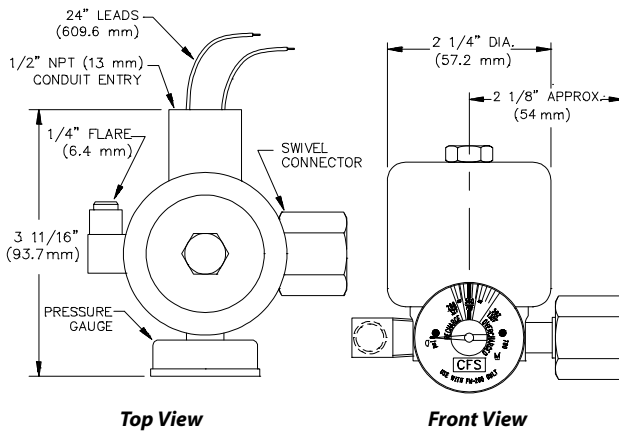

Stock Number	Description
20610255	Solenoid pilot valve assembly 120V-60Hz/24VDC
20610256	Explosionproof Solenoid pilot valve assembly 24 VDC
20610257	Solenoid pilot valve assembly with supervisory pressure switch 120V-60Hz/24VDC

Manual-Pneumatic Actuator - S/N 10610729

This device is required for the manual actuation of a cylinder and is attached to a check valve connection port. This is a dual purpose device, having an actuating piston connected to a pin to upset the fill check valve when pilot pressure is applied to the piston. With the check valve open, cylinder pressure is applied through the pilot connection to the operating piston of the Beta valve, thereby opening the cylinder to discharge its contents.

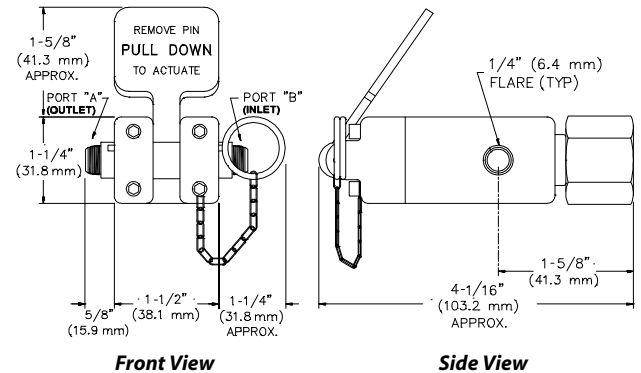

Discharge Tube Assembly - S/N 20480335

A formed, 1-1/2 in. (40 mm) O.D. steel tube assembly with a flare nut at each end is used to connect the cylinder valve to a male connector, which can then be connected to the discharge piping system.

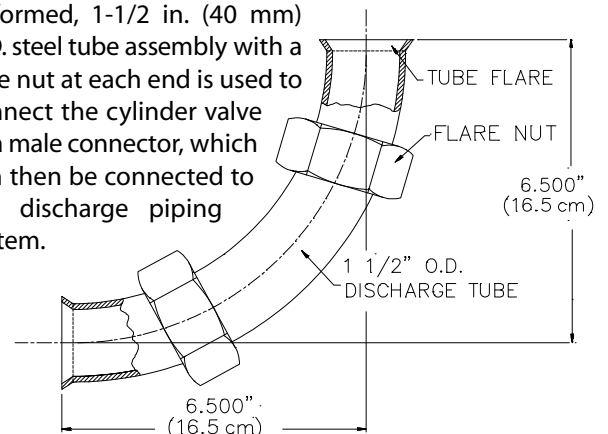

CHEMETRON Fire Systems™ FM-200™ Beta Series Systems

Discharge Connection Fitting - S/N 70440009

A 1-1/4 in. (32 mm) male connector is used to attach a cylinder to the discharge piping system.

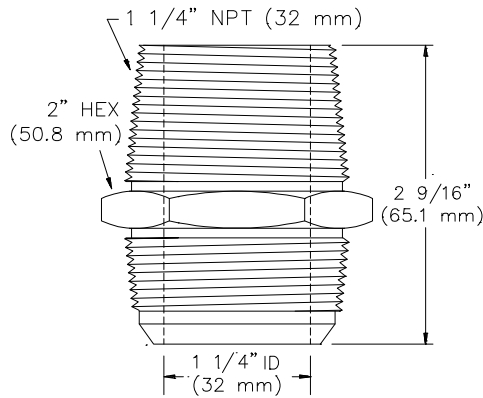

Flexible Connector

Lengths of 3/16 in. (5 mm) flexible connectors are used to interconnect the cylinder valve devices. These hoses have a stainless steel wire braid cover and a teflon liner, and are fitted at each end with a 1/4 in. swivel flare nut.

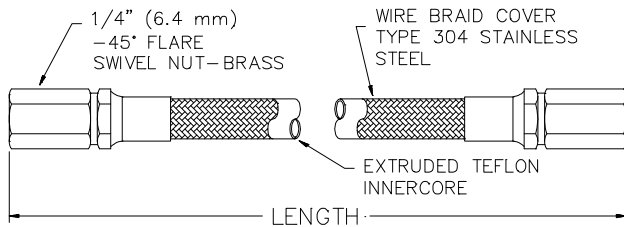

Stock Number	Description
10260260	3/16 in. (5 mm) Connector 16 in. (40.6 cm) long
10260267	3/16 in. (5 mm) Connector 20 in. (50.8 cm) long
10260303	3/16 in. (5 mm) Connector 28 in. (71.1 cm) long

Pressure Gauge Assembly

In systems requiring more than one cylinder, a pressure gauge assembly is required for each cylinder other than the pilot cylinder as a means of visual surveillance of the pressure condition within the cylinder.

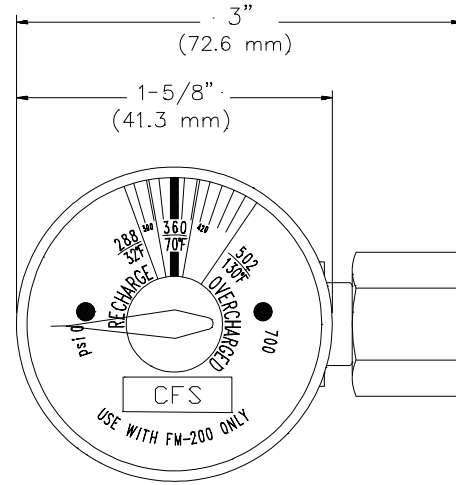

Pressure Gauge

Stock Number	Description
20240040	Pressure Gauge Assembly
20610258	Pressure Gauge Assembly w/supervisory pressure switch

OPTIONAL EQUIPMENT

Pressure Switch - S/N 10170089

A pressure switch is used in the system to implement the shut down of power and various items of equipment, such as fans; and for annunciation and alarm purposes. An explosionproof pressure switch is also available.

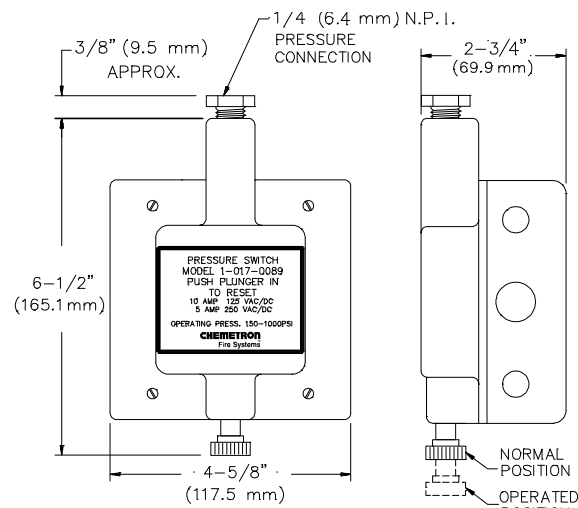

CHEMETRON Fire Systems™ FM-200™ Beta Series Systems

Check Valve - S/N 10610732

A check valve is used between the cylinder valve discharge outlet flexible connection and the discharge manifold. The check valve prevents back flow from the manifold in the event that the system is discharged when one or more cylinders are disconnected, such as for weighing or general servicing. A check valve is not required on single cylinder systems.

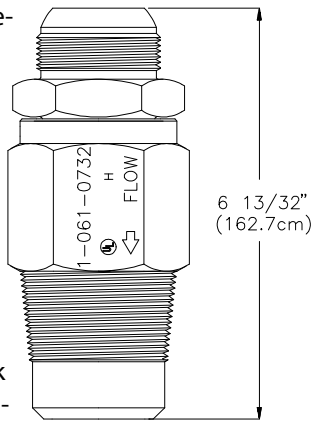

CYLINDER RACK

Single/Multiple Cylinders, Vertically Mounted S/N 20710268

The cylinder rack, consisting of a rail, a strap, and miscellaneous hardware for interconnection, is shipped unassembled. The rail is provided with 1-1/8 in. (2.85 cm) slots on 2 in. (5.0 cm) centers for mounting bolts.

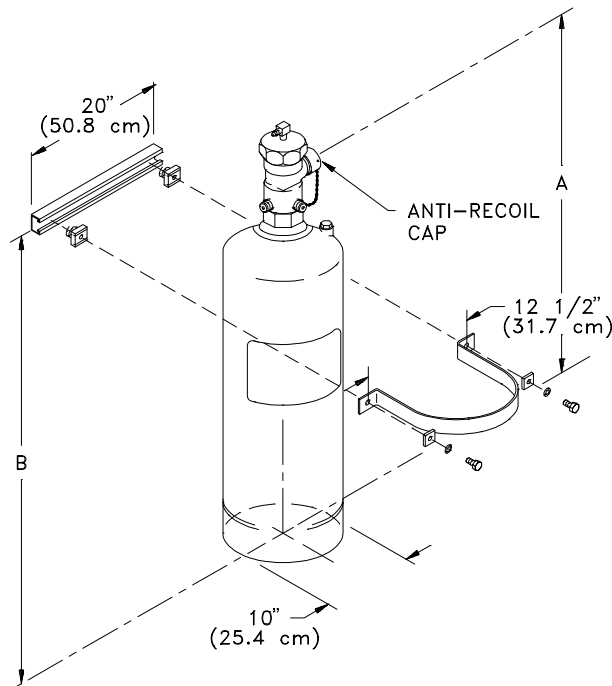

Stock Number	Nominal Cylinder Size	Dimension			
		A		B	
		in	cm	in	cm
10480992	40 lb.	20 9/16	52.1	12 1/4	31.1
10480980	55 lb.	25 3/8	64.4	14	35.5
10480991	95 lb.	38 5/8	98.1	22 3/4	57.8

Stock Number	Empty Cylinder Weight Lb (Kg)	Cylinder Assembly Dimensions			
		Height		Diameter	
		in	cm	in	cm
10480992	38 (17)	23 5/16	60.4	10	25.4
10480980	50 (23)	28 1/8	71.4	10	25.4
10480991	65 (30)	41 3/8	105.1	10	25.4

NOZZLES

Nozzles (8 port) are used to control the flow of FM-200 to insure it is discharged within 10 seconds and properly distributed in the protected hazard.

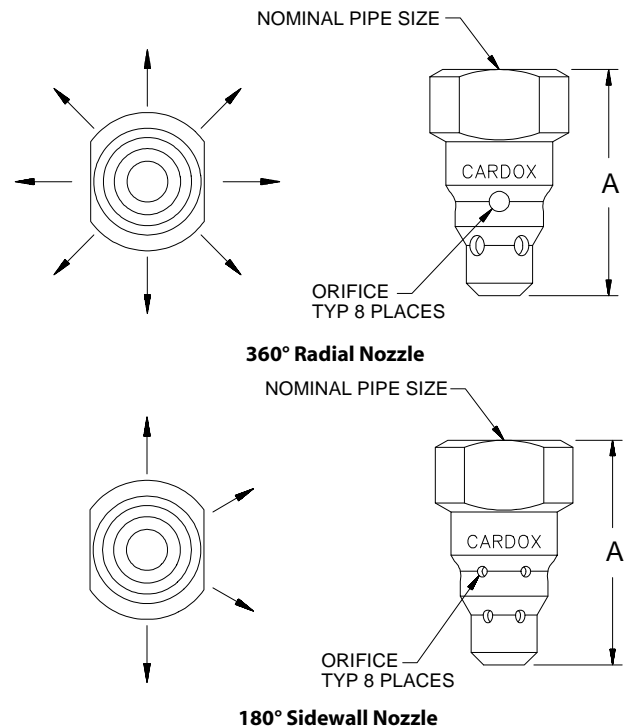

Stock Number		Nominal Pipe Size	Nozzle Height	
			A	
Stainless	Brass		in	mm
■ 360° Radial Nozzle				
10371360	10371415	3/8 in (9.5 mm)	2.031	51.6
10371361	10371416	1/2 in (12.7 mm)	2.250	57.2
10371362	10371417	3/4 in (19.05 mm)	2.688	68.3
10371363	10371418	1 in (25.4 mm)	2.875	73.0
10371364	10371419	1-1/4 in (31.75 mm)	3.250	82.6
10371365	10371420	1-1/2 in (38.1 mm)	3.625	92.1
10371366	10371421	2 in (50.8 mm)	4.500	114.3
■ 180° Sidewall Nozzle				
10371407	10371423	3/8 in (9.5 mm)	2.031	51.6
10371408	10371424	1/2 in (12.7 mm)	2.250	57.2
10371409	10371425	3/4 in (19.05 mm)	2.688	68.3
10371410	10371426	1 in (25.4 mm)	2.875	73.0
10371411	10371427	1-1/4 in (31.75 mm)	3.250	82.6
10371412	10371428	1-1/2 in (38.1 mm)	3.625	92.1
10371413	10371429	2 in (50.8 mm)	4.500	114.3

PHYSICAL/CHEMICAL PROPERTIES

FM-200 (CF₃CHF₂ - heptafluoropropane) is a compound that consists of carbon, fluorine and hydrogen. It is colorless, odorless, electrically non-conductive, and suppresses fire by interrupting the combustion process and affecting the available oxygen content in the area of the discharge.

FM-200 is clean, efficient, environmentally acceptable, and leaves no residue, thus minimizing any downtime after a fire.

If exposed to temperatures greater than 1300°F, toxic products of decomposition (hydrogen fluoride) are formed. The system is designed to discharge in 10 seconds or less to minimize the amount of toxic byproduct formed during extinguishment of flames. Most materials contained in areas protected by FM-200, such as aluminum, brass, rubber, plastics, steel, and electronic components, are unaffected when exposed to FM-200.

FM-200 is stored as a liquid in steel containers and super-pressurized with nitrogen to 360 psig (2482 kPa) to increase its discharge flow characteristics. When discharged, FM-200 will vaporize at the discharge nozzles and effectively mix with the air throughout the protected area.

SAFETY CONSIDERATIONS

In accordance with NFPA Standard 2001 and the EPA Significant New Alternative Program (SNAP), personnel exposure to FM-200 total flooding system concentrations shall be limited to the following:

The discharge of FM-200 into a hazard may cause a reduction in visibility for a brief period. Any direct contact with the agent can cause frostbite.

A cylinder containing FM-200 should be carefully handled. **All anti-recoil devices must be in place at all times when the cylinder is not restrained.**

The Material Safety Data Sheet (MSDS) covering FM-200 should be read and understood prior to working with the agent.

Concentration Level	Exposure Restriction
9% or below (current NOAEL)	No restriction
Above 9%, up to 10.5%	Limit to 1 minute
Greater than 10.5% (current LOAEL)	Avoid any exposure

The seller makes no warranties, express or implied, including, but not limited to, the implied warranties of merchantability and fitness for a particular purpose, except as expressly stated in seller's sales contract or sales acknowledgment form. Every attempt is made to keep our product information up-to-date and accurate. All specific applications cannot be covered, nor can all requirements be anticipated. All specifications are subject to change without notice.

