

GENERAL INFORMATION

The Chemetron Fire Systems Alpha Series Systems are automatic suppression systems using the FM-200 chemical agent and consisting of four basic components and their associated accessories.

- FM-200 Components
- Completer Kits
- Control Panels
- Detection and Alarm Devices

Features

- 1** The FM-200 components consist of agent containers, container supports (wall mounted rack kits) and discharge nozzles.
- 2** The completer kits consist of warning signs, hoses, connection fittings, pressure gauges or solenoid valves, and the discharge head required to operate the cylinder valve.
- 3** The control panel monitors the detection, actuates the alarms, initiates the agent discharge and controls auxiliary functions such as shut down of vital equipment and ventilation dampers.
- 4** The detection, alarm devices and accessories provide fire detection, audible and visual pre-alarm warnings and annunciation of the FM-200 discharge.

The system and its components are agency tested for total flooding applications and should be used in accordance with the guidelines contained in National Fire Protection Association 2001. A total flooding application can be defined as injecting FM-200 into an enclosure or volume having the structural integrity to retain the agent during and after discharge. The design of such a system requires that the FM-200 chemical agent be discharged from its container within 10 seconds and be thoroughly mixed throughout the protected volume, reaching a minimum concentration level of 7%, but not exceeding 9% in normally occupied spaces.

ALPHA SERIES SYSTEM EQUIPMENT DESCRIPTION

Cylinder and Valve Assembly

Alpha Series cylinders are available in two different capacities and are charged with FM-200 to a filling density up to 70 lb/ft³ (1121 kg/m³) of cylinder volume. All cylinders are superpressurized with dry nitrogen to a pressure of 360 psig (2482 kPa), at 70°F (21°C). Each cylinder is equipped with an identification nameplate indicating the quantity of FM-200.

The standard cylinder assembly is composed of a cylinder, dip tube and cylinder valve. A pilot completer kit is also required for actuation.

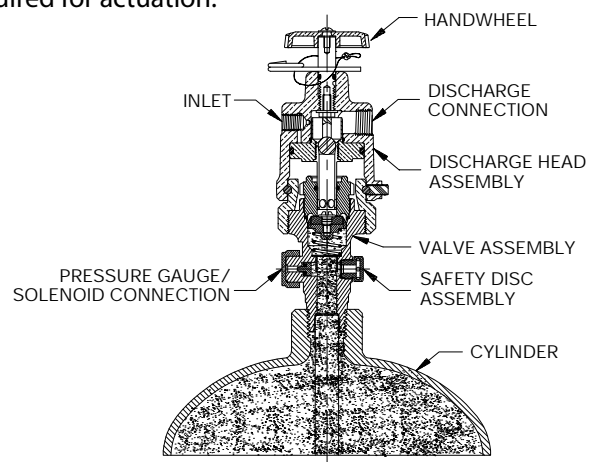
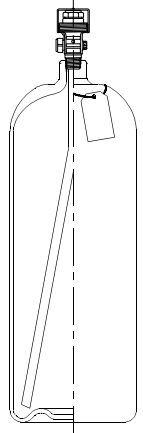

Cylinder Valve - Standby Mode

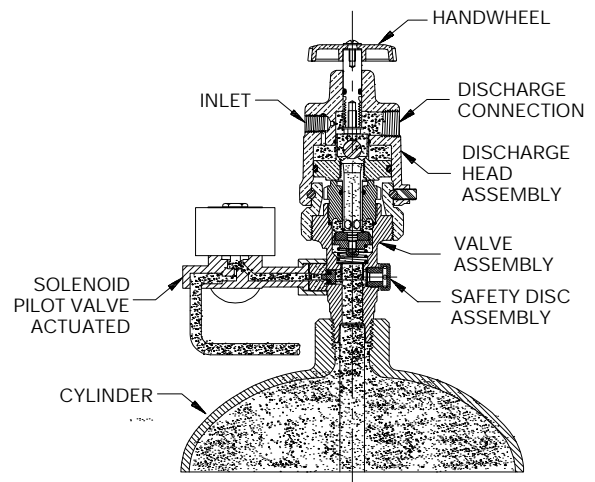

Cylinder Valve - Actuated (Solenoid or Handwheel)

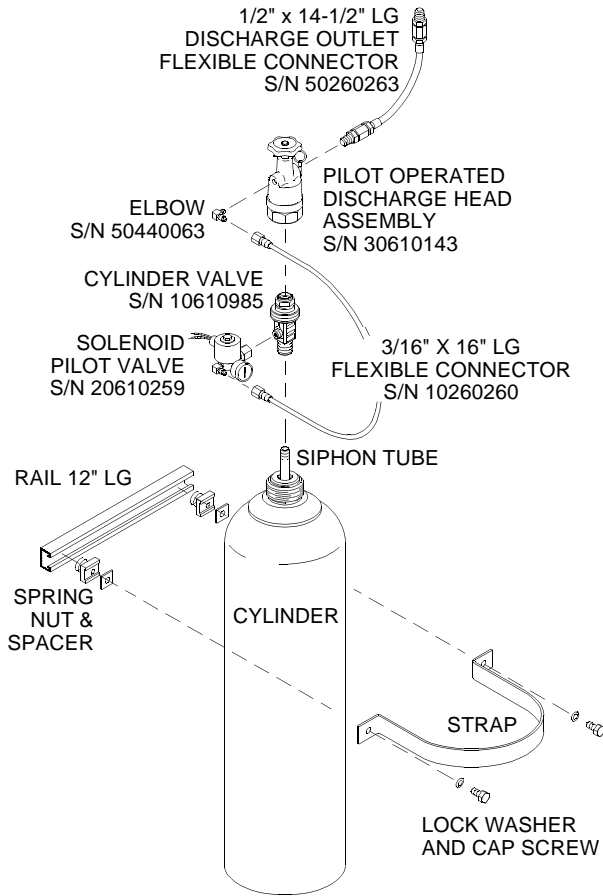

Alpha Series FM-200 Cylinder Assembly with Completer Kit and Mounting Bracket

Cylinder	Stock Number	Fill Capacity			
		Minimum		Maximum	
		lbs	kg	lb	kg
10 lb.	10481482	6	2.7	12	5.4
20 lb.	10481483	12	5.4	23	10.4

A Cylinder: The welded seam steel cylinders are manufactured to the requirements of the Department of Transportation (DOT) for compressed gas and have internal neck threads for cylinder valve connection.

B Dip Tube: A threaded dip tube extends from the cylinder valve down to within approximately 1/2 in. (13 mm) of the bottom of the cylinder.

C Discharge Head: Each cylinder requires the addition of a discharge head to open its valve. The discharge head is attached to the cylinder by means of a swivel nut that engages the threads of the valve. The pilot operated discharge head is provided with a handwheel to allow for manual operation. It includes an internal operating piston connected to a hollow stem that is used to upset the cylinder seat disc when operated, which allows the agent to exit.

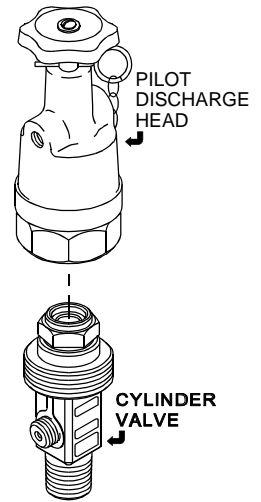

D Cylinder Valve: When fitted with the pilot discharge head, the cylinder valve becomes a pressure differential type cylinder valve having a forged brass body with a seat disc held in the normally closed position by a spring and cylinder pressure. The valve has been designed to take advantage of the pilot head's 7 to 1 seat to piston ratio, which assures consistent operation. It is attached to the cylinder neck and serves to control the flow of FM-200 from the cylinder. The valve is secured to the cylinder by means of 1" - 11-1/2 NPT pipe threads and is sealed by a cylinder O-ring. A synthetic rubber seat is attached to a brass seat retainer, which is screwed into the bottom of the valve. The seat retainer also supports the dip tube. The body is designed with multiple threaded connections that accommodate the discharge head and cylinder. In addition the following three connections are provided:

1 Pressure Gauge/Solenoid Pilot Valve Assembly Connection: This is a threaded connection housing a check valve and serves for the attachment of a solenoid pilot valve assembly (with pressure gauge).

2 Safety Disc Connection: A frangible safety disc assembly serves to protect the cylinder against excessive internal pressure. The disc is designed to burst in a range of 850 psi to 1000 psi (5860 kPa to 6895 Kpa).

3 Discharge Connection: A 1/2" (13 mm) NPT connection serves as the discharge port.

COMPLETER KIT

A primary completer kit, with or without a supervisory pressure switch, is required to complete the installation of each FM-200 Alpha cylinder. The components included in the completer kit are detailed in the following chart.

Description	Primary Completer Kit	
	Without Supervisory Pres. Switch 20480759	With Supervisory Pres. Switch 20480760
	Quantity	Quantity
Solenoid valve	1	0
Solenoid valve w/Supervisory Pressure Switch	0	1
Discharge head, pilot	1	1
3/16" flex hose 16" long	1	1
1/2" flexible discharge connector	1	1
Elbow 1/4" flare x 1/4" MNPT	1	1
Warning sign	1	1
Cylinder Nameplate	1	1
If cylinders are used in a Main/Reserve system, order decals: Main Decal - S/N 50360753 Reserve Decal - S/N 50360752		

Pilot Operated Discharge Head with Handwheel

Stock Number 30610143

This discharge head is designed with a 1/4" (6 mm) NPT connection for pilot pressure entry to the top of an internal piston for valve operation. It is used on the actuation cylinders. This head also operates when pressure from the manifold is applied to the piston. To prevent accidental discharge, the discharge head contains an internal vent opening to prevent the accumulation of pressure on the piston if leakage should occur through the solenoid valve.

The discharge head is also provided with a handwheel for manual operation, which is independent of a need of electric power. The handwheel is turned counterclockwise for operation.

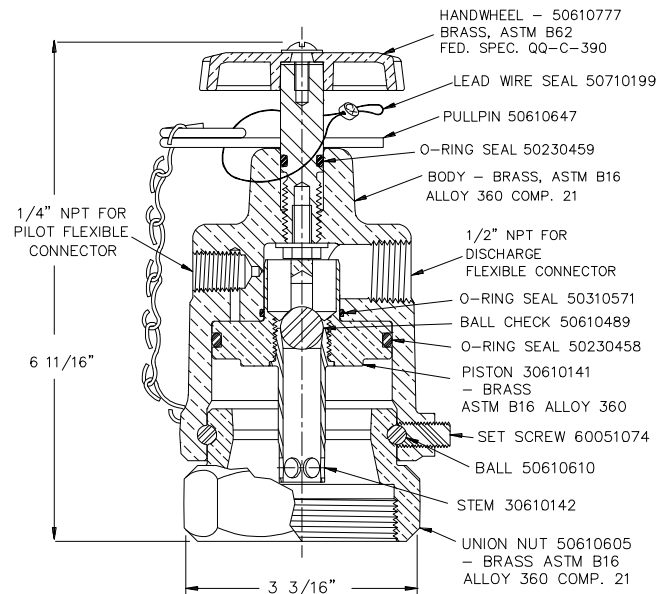

Pilot Operated Discharge Head with Handwheel

Solenoid Pilot Valve Assembly

The system utilizes a solenoid pilot valve assembly to provide pilot pressure for actuation and must be electrically supervised by a recognized fire suppression system control panel. The solenoid pilot valve assembly includes a pressure gauge and adapter with swivel nut, elbow, and O-ring seal that is attached to the pressure gauge connection of the cylinder valve.

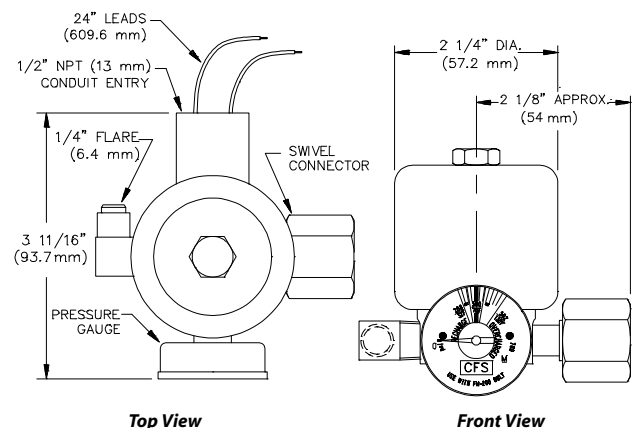

Top View

Front View

Stock Number	Description
20610259	Solenoid pilot valve assembly 120V-60Hz/24VDC
20610260	Explosionproof Solenoid pilot valve assembly 24 VDC
20610261	Solenoid pilot valve assembly with supervisory pressure switch 120V-60Hz/24VDC

Flexible Connector

A 3/16 in. (5 mm) flexible connectors is used to interconnect the cylinder valve devices. This hose has a stainless steel wire braid cover and a Teflon liner, and is fitted at each end with a 1/4 in. swivel flare nut.

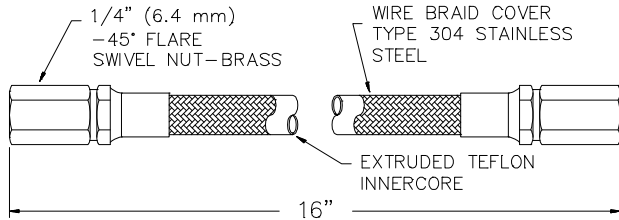

Stock Number	Description
10260260	3/16 in. (5 mm) Hose with 1/4 in. (6 mm) Connector - 16 in. (40.6 cm) long

Flexible Discharge Connector

Stock Number 50260263

A 1/2" (13 mm) flexible discharge connector (14-1/2" long) is used to connect each discharge head to a cylinder manifold or outlet pipe. The hose is Teflon lined with an outer stainless steel wire braid cover. There are 1/2" (13 mm) male pipe thread connections on one end. One end contains a union joint for easy make-up without twisting, while the other has a coupling with male adapter for easy installation.

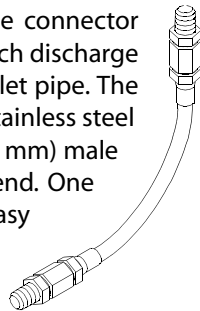

OPTIONAL EQUIPMENT

Pressure Switch

A pressure switch is used in the system to implement the shut down of power and various items of equipment, such as fans; and for annunciation and alarm purposes.

Stock Number	Description
10170089	2 Pole Pressure Switch <i>indoor use only</i>
70170229	Explosionproof 3 Pole Pressure Switch
10170065	4 Pole Pressure Switch <i>weatherproof</i>

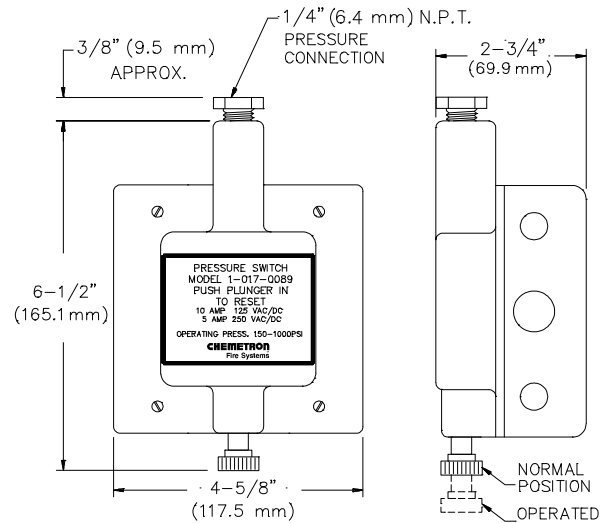

Pressure Switch (S/N 10170089 shown)

Check Valve

Stock Number 10610329 - 1/2"

Stock Number 10610330 - 3/4"

Check valves in sizes 1/2" and 3/4" NPT (13 and 19 mm) are used to isolate the main cylinder manifold from the connected reserve cylinder manifold so that a discharge from one will not enter the other and cause actuation of that bank of cylinders.

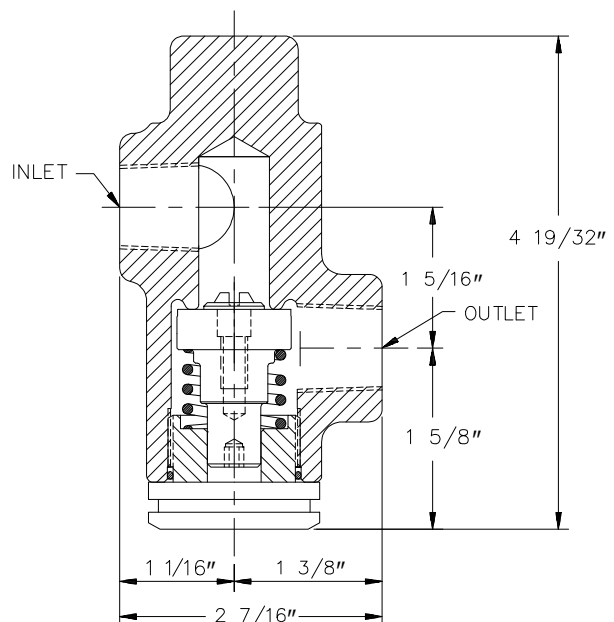

A 1/2" (13 mm) bleeder valve (S/N 10610573) is also recommended in both the main and reserve manifolds.

CYLINDER RACK

Vertically Mounted Cylinders

The cylinder rack, consisting of a rail, a strap, and miscellaneous hardware for interconnection, is shipped unassembled. The rail is provided with 1-1/8 in. (2.85 cm) slots on 2 in. (5.0 cm) centers for mounting bolts.

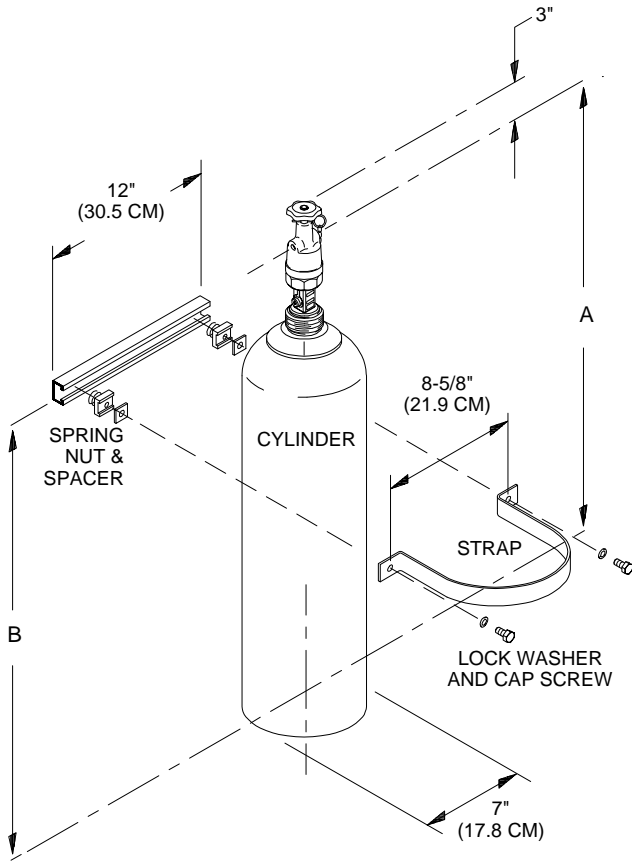

Rack Kit Stock Number 20710369

Stock Number	Nominal Cylinder Size	Dimension			
		A		B	
		in	cm	in	cm
10481482	10 lb.	11-11/16	29.7	5-1/2	14.0
10481483	20 lb.	19-3/8	49.2	10	25.4

Stock Number	Empty Cylinder Weight Lb (Kg)	Cylinder Assembly Dimensions			
		Height		Diameter	
		in	cm	in	cm
10481482	11 (5)	14-11/16	37.3	7	17.8
10481483	15 (6.8)	22-3/8	56.8	7	17.8

NOZZLES

Nozzles (8 port) are used to control the flow of FM-200 to insure it is discharged within 10 seconds and properly distributed in the protected hazard.

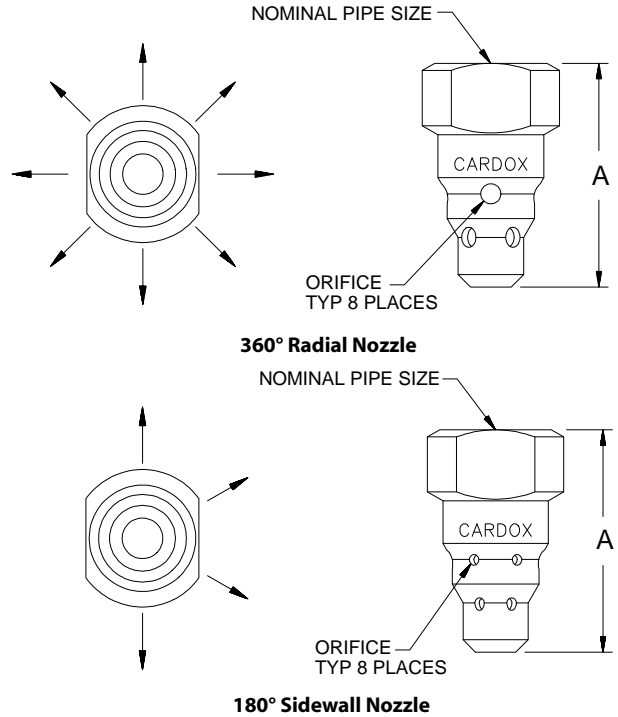

Stock Number		Nominal Pipe Size	Nozzle Height	
Stainless	Brass		A	
			in	mm
■ 360° Radial Nozzle				
10371360	10371415	3/8 in (10 mm)	2.031	51.6
10371361	10371416	1/2 in (13 mm)	2.250	57.2
10371362	10371417	3/4 in (19 mm)	2.688	68.3
10371363	10371418	1 in (25 mm)	2.875	73.0
10371364	10371419	1-1/4 in (32 mm)	3.250	82.6
10371365	10371420	1-1/2 in (38 mm)	3.625	92.1
10371366	10371421	2 in (51 mm)	4.500	114.3
■ 180° Sidewall Nozzle				
10371407	10371423	3/8 in (10 mm)	2.031	51.6
10371408	10371424	1/2 in (13 mm)	2.250	57.2
10371409	10371425	3/4 in (19 mm)	2.688	68.3
10371410	10371426	1 in (25 mm)	2.875	73.0
10371411	10371427	1-1/4 in (32 mm)	3.250	82.6
10371412	10371428	1-1/2 in (38 mm)	3.625	92.1
10371413	10371429	2 in (51 mm)	4.500	114.3

PHYSICAL/CHEMICAL PROPERTIES

FM-200 (CF₃CHF₂CF₃ - heptafluoropropane) is a compound that consists of carbon, fluorine and hydrogen. It is colorless, odorless, electrically non-conductive, and suppresses fire by interrupting the combustion process and affecting the available oxygen content in the area of the discharge.

FM-200 is clean, efficient, environmentally acceptable, and leaves no residue, thus minimizing any downtime after a fire.

If exposed to temperatures greater than 1300°F, toxic products of decomposition (hydrogen fluoride) are formed. The system is designed to discharge in 10 seconds or less to minimize the amount of toxic byproduct formed during extinguishment of flames. Most materials contained in areas protected by FM-200, such as aluminum, brass, rubber, plastics, steel, and electronic components, are unaffected when exposed to FM-200.

FM-200 is stored as a liquid in steel containers and superpressurized with nitrogen to 360 psig (2482 kPa) to increase its discharge flow characteristics. When discharged, FM-200 will vaporize at the discharge nozzles and effectively mix with the air throughout the protected area.

SAFETY CONSIDERATIONS

In accordance with NFPA Standard 2001 and the EPA Significant New Alternative Program (SNAP), personnel exposure to FM-200 total flooding system concentrations shall be limited to the following:

The discharge of FM-200 into a hazard may cause a reduction in visibility for a brief period. Any direct contact with the agent can cause frostbite.

A cylinder containing FM-200 should be carefully handled. **The protective cap must be in place at all times when the cylinder is not restrained.**

The Material Safety Data Sheet (MSDS) covering FM-200 should be read and understood prior to working with the agent.

Concentration Level	Exposure Restriction
9% or below (current NOAEL)	No restriction
Above 9%, up to 10.5%	Limit to 1 minute
Greater than 10.5% (current LOAEL)	Avoid any exposure

The seller makes no warranties, express or implied, including, but not limited to, the implied warranties of merchantability and fitness for a particular purpose, except as expressly stated in seller's sales contract or sales acknowledgment form. Every attempt is made to keep our product information up-to-date and accurate. All specific applications cannot be covered, nor can all requirements be anticipated. All specifications are subject to change without notice.

